

According to current research infectious droplets are the primary mode of transmission for the COVID-19 virus. This mainly occurs when an infected person with respiratory symptoms coughs or sneezes within close contact (1m) of another person. Patient screens are an affordable and practical option for reducing the spread of infection in wards or waiting rooms, acting as a barrier between patients

The following guide outlines a low-cost, self supporting patient screen built out of a steel frame and nylon tarp that can easily be assembled for use in various low-resource settings.

1. Welded Steel Frame

Provides a stable, self supporting structure for the screen

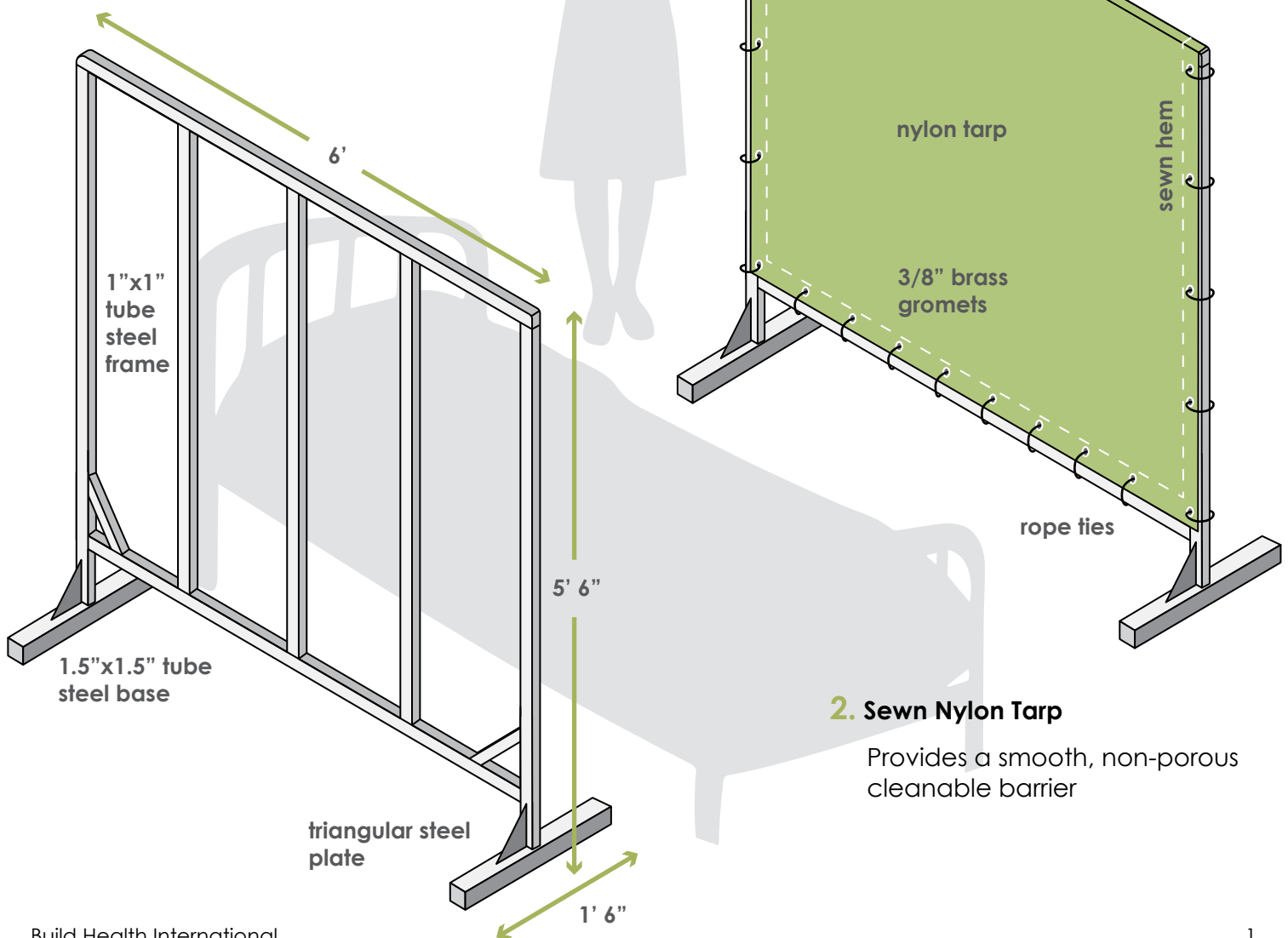

2. Sewn Nylon Tarp

Provides a smooth, non-porous cleanable barrier

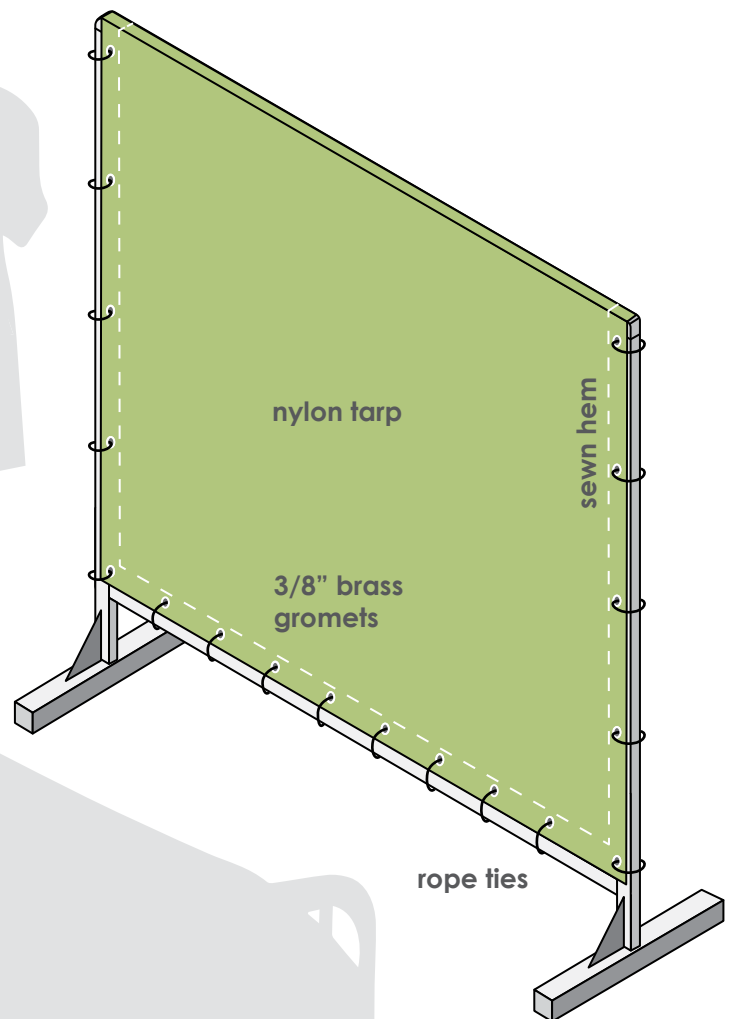

1. Welded Steel Frame Details

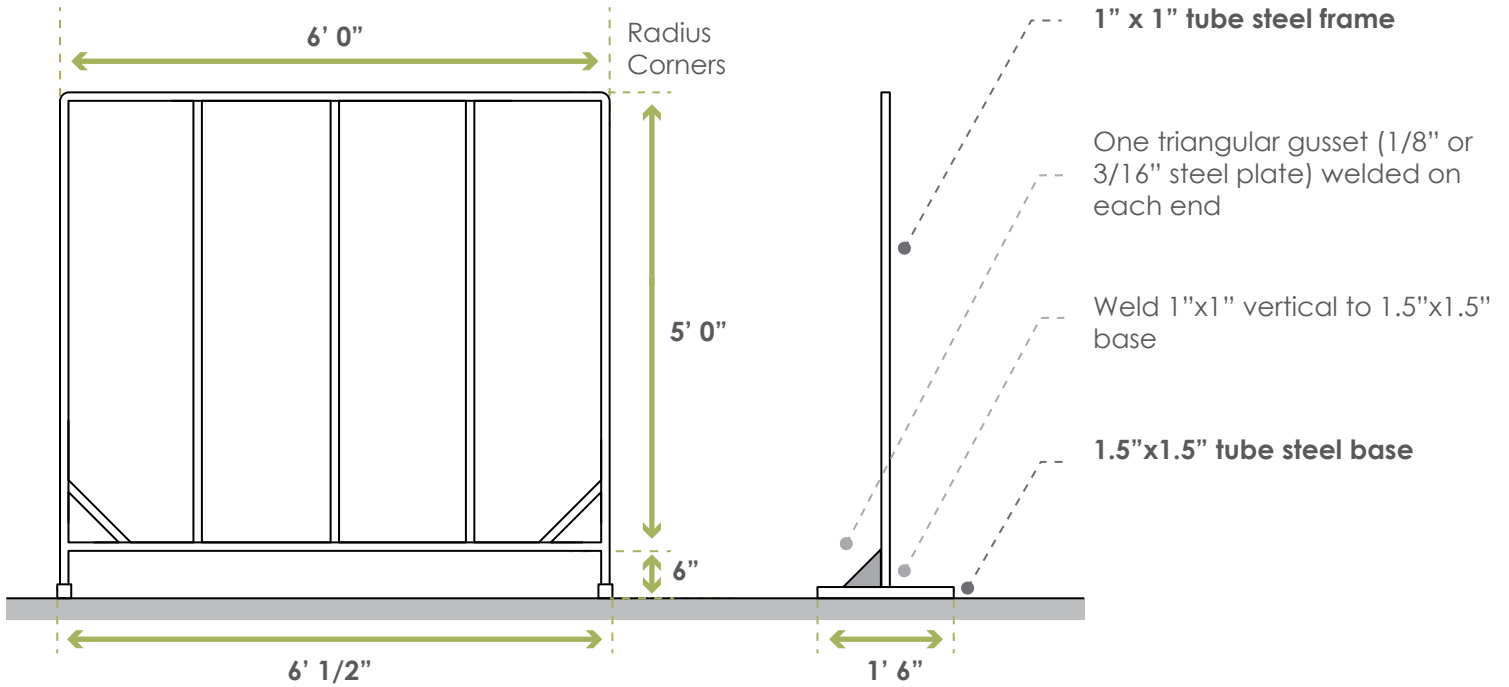

2. Sewn Nylon Tarp

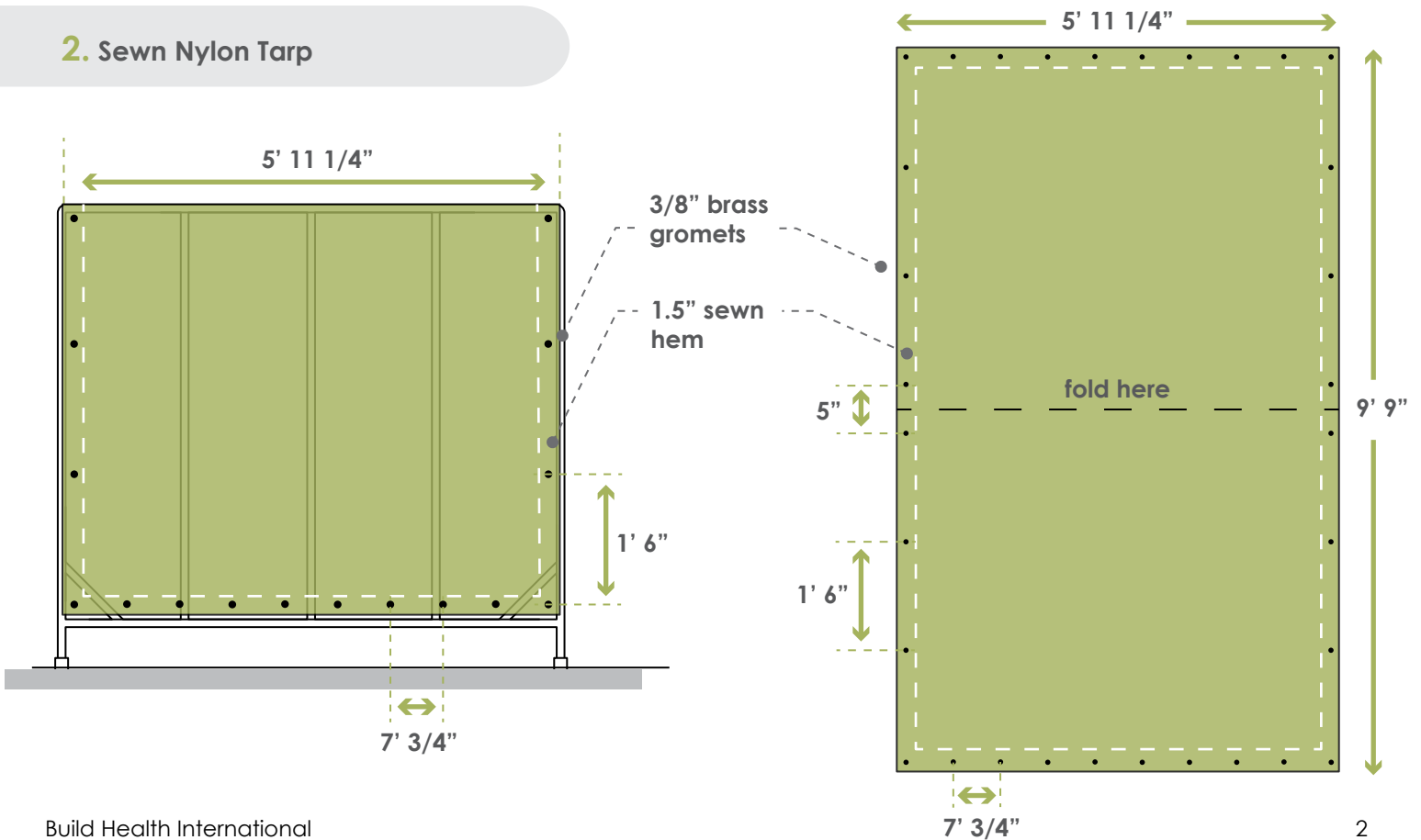

1" x 1" Tube steel

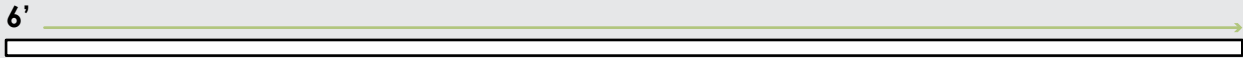
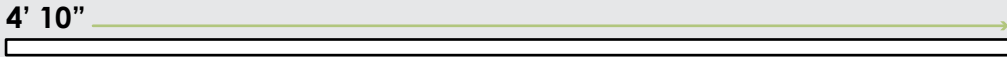
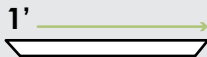
- A** 6'  x 2
- B** 4' 10"  x 5
- C** 1'  (ends cut to 45° angle) x 2
- D** 4.5"  x 2

1.5" x 1.5" Tube steel

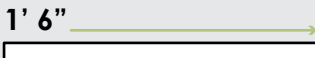
- E** 1' 6"  x 2

3/16" or 1/8" Steel plate

- F** 5.5"  x 2

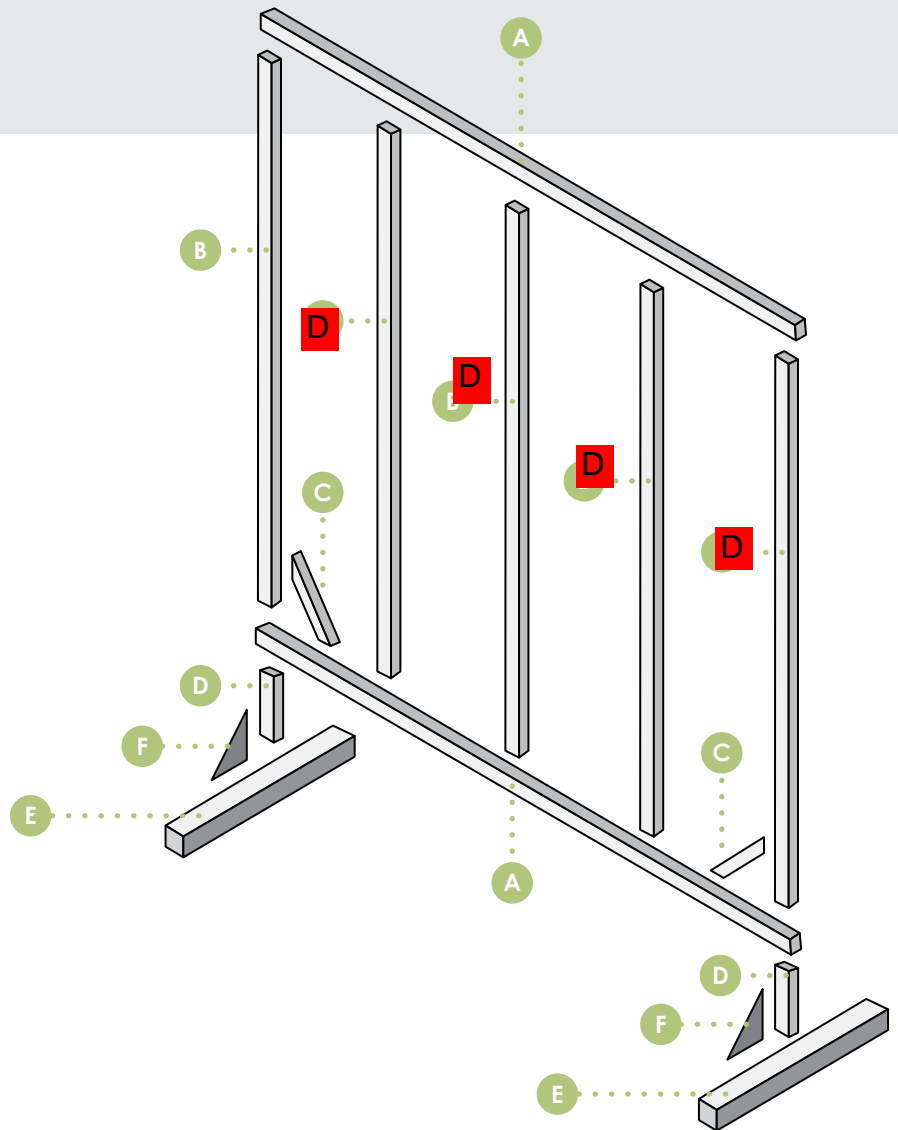

Assembly Instructions

1. Lay material on a flat surface and cut all parts of metal frame to the correct size (see pg xx). Note that tube steel is typically sold in lengths of 24' (7.3m). Plan your cuts to minimize waste.
2. Clean metal parts thoroughly removing metal shavings, rust, oil and dirt.
3. Tack weld metal frame pieces **A to B**
4. Measure both diagonals to verify the frame is square. Each diagonal should be around 7' 10"
5. when square tack in diagonal braces "C"
6. Add vertical supports "D", tack weld in place

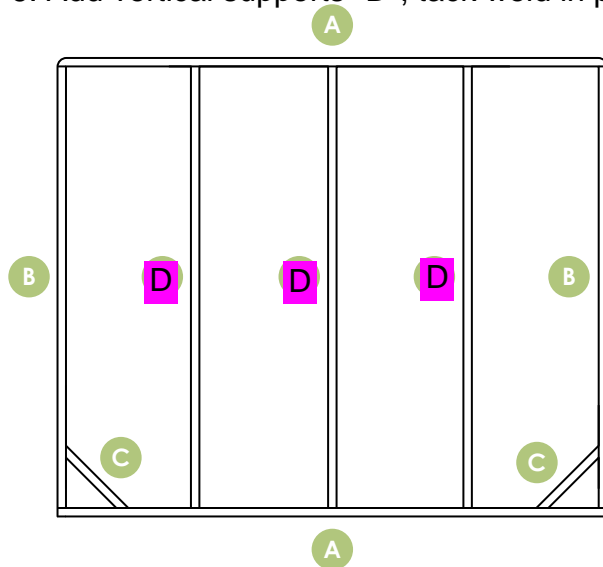

Tack weld pieces A - D

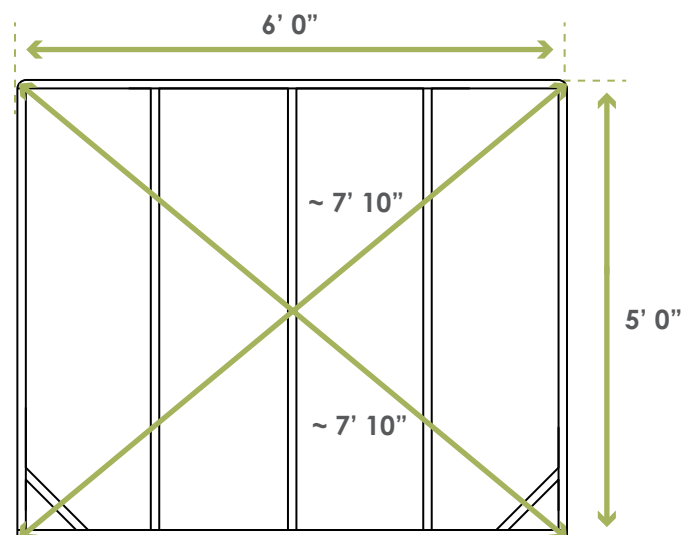

Measure diagonals

7. make sure frame is flat and square.
5. Tack weld frame pieces D - F to form the base feet.
6. Finish metal frame with a continuous weld along all joints. Note that depending on the quality of steel the walls of the tubes may be very thin (less than 2mm thick). Be careful when welding to not burn through the metal.

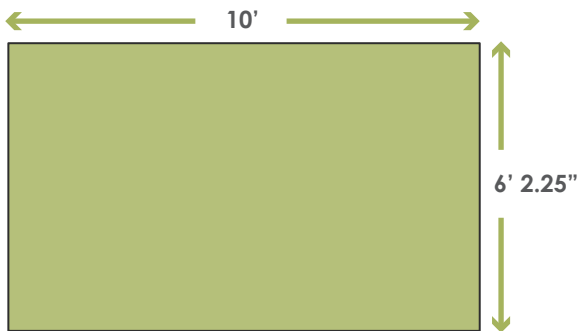

1. Cut out 10' x 6' 2.25" nylon heavy duty tarp

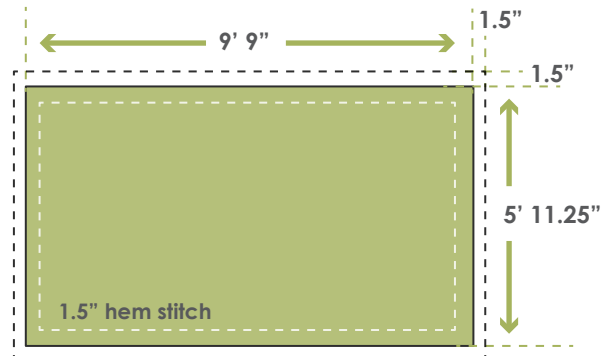

2. Fold and hem 1.5" inches around all edges.

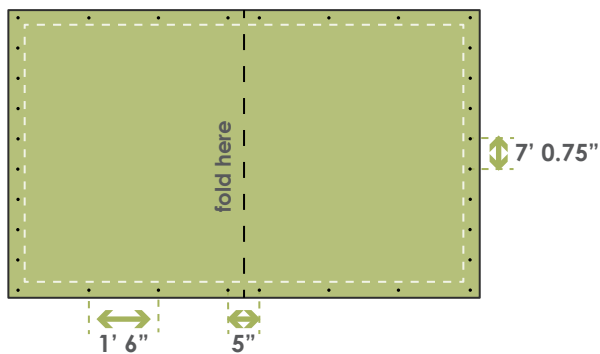

3. Measure out and mark all 32 grommet holes.

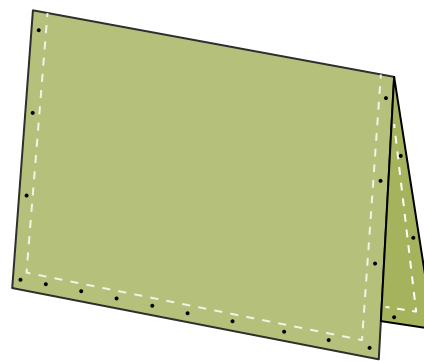

4. Ensure all the grommet holes line up when the fabric is folded over before installing grommets.

Grommet Kits

A grommet is a metal ring used to reinforce holes in fabric. Grommet kits consist of grommet tubes and washers, a hole cutter, a metal punch and anvil. You will also need a flat surface like a wooden block and a hammer. Grommet kits are affordable and easily available.

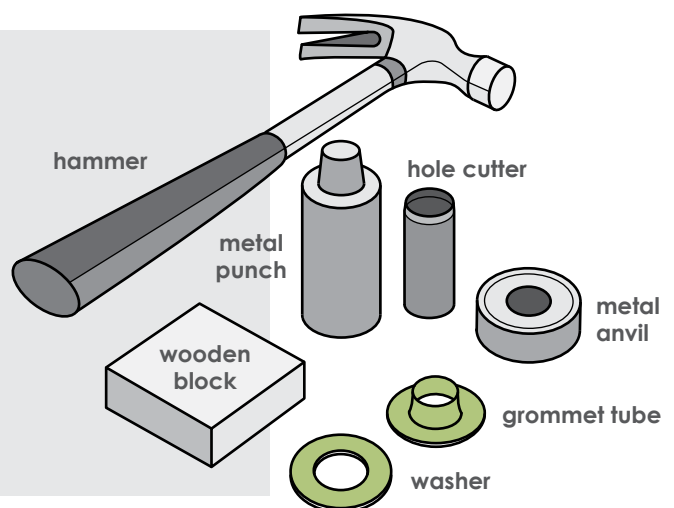

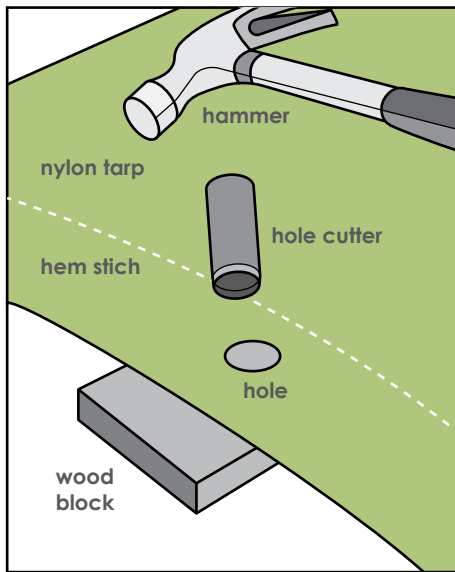

1. Slide a wood block under the marked grommet location. Align the hole cutter over the mark and strike it sharply with a hammer until it punches through the tarp.

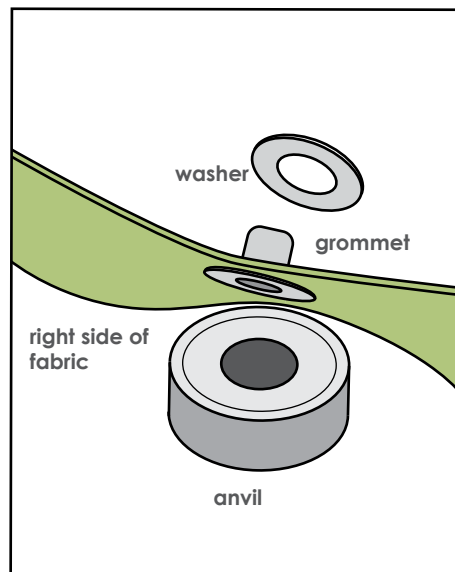

2. Place the grommet tube from the right side of the fabric. Place the washer on the other side, teeth side down. Position the grommet over the anvil.

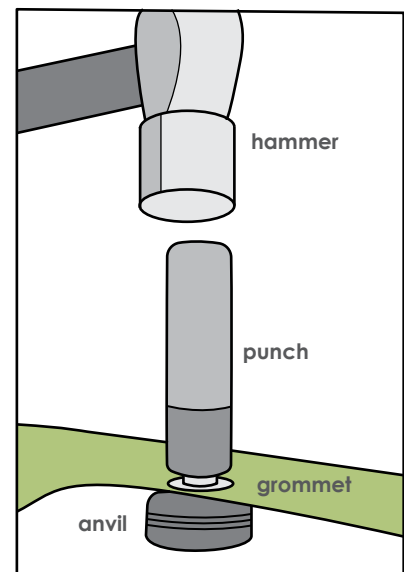

3. Position the punch into the grommet tube and through the anvil center. Strike the punch firmly with a hammer until the grommet and washer fit tightly together.

4. Take care to round and deburr all sharp edges before attaching the finished nylon tarp covering.

5. Fold the tarp over along its long length and position it over the frame

6. Pull the tarp tight at the bottom middle first then each lower corner to get the tarp stretched out as tightly and smoothly and possible.

7. Cut out xx' of rope and proceed to tie and wrap the tarp to the frame *(do graphic for this)*

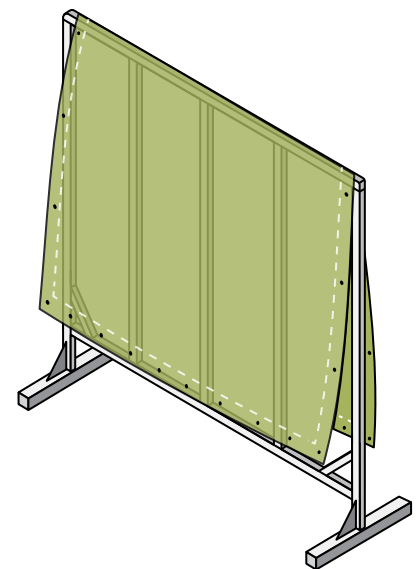

Bill of Materials per Patient Screen

MATERIAL	QUANTITY	UNIT COST	TOTAL COST
1" x 1" Tube Steel	46'	\$ 7.95	
1.5" x 1.5" Tube Steel	3'	\$ 14.00	
Nylon Heavy Duty Tarp	6' 3/4" x 9' 10 1/2"	\$ 68.00	
Synthetic Rope (4mm)	15?	\$ 0.05	
3/16" or 1/8" Steel Plate	(5.5" x 5.5" Sq then cut diagonally)	\$ 145.00	
3/8" Grommets	32	\$ 0.16	
		Total	

Check Price-Too High

Price seems High Andrew pls check

Nylon Braided Rope

This is for entire sheet

Equipment and Skills needed

- Grommet tool kit
- Sewing machine/seamstress
- Welding consumables/~~contract~~ welder